

Eco-Jet-G / -GD

**Grease Separators – Free-standing Installation – Full Disposal –
Separated Chambers Design – PE-HD**



Type
Eco-Jet-G NS 2
Eco-Jet-G NS 4



Type
Eco-Jet-GD NS 2
Eco-Jet-GD NS 4



For a safe and proper use, read operating manual and further product-supporting documents thoroughly. Hand on documents to end user.

ACO Passavant GmbH

Ulsterstrasse 3

36269 Philippsthal

Telephone +49 (0) 36965 819 - 0

Telefax +49 (0) 36965 819 - 361

www.aco-haustechnik.de

Contents

1. Preamble	5
1.1 ACO service.....	5
1.2 Product identification	5
1.3 Product-related documents	5
1.4 Warranty	6
1.5 Field of application of operating manual	6
1.6 Important addresses	6
1.7 Regulations and standards.....	7
1.7.1 Wastewater treatment by installation of grease separators.....	7
1.7.2 Special legal and technical regulations.....	7
1.7.3 Inflow conditions	7
1.7.4 Limited application	8
1.7.5 Drain points.....	8
1.7.6 Installation location.....	9
1.7.7 Inlet line.....	9
1.7.8 Vent line.....	10
1.7.9 Disposal line.....	10
1.7.10 Sampling appliance, sampling.....	10
1.7.11 Sewer connection	11
1.7.12 Disposal	11
1.7.13 Maintenance	11
1.7.14 General inspection (check)	12
1.7.15 Operating log	12
2. Safety.....	13
2.1 Proper use	13
2.1.1 Field of application	13
2.1.2 Product design limits	13
2.2 Plagiarisms/non-approved parts.....	13
2.3 Basic risk potential.....	13
2.4 Symbols and reference notes explanations.....	14
2.5 Safety notes	14
2.5.1 Endangering in the case of non-observance of safety notes.....	14
2.5.2 Safety-conscious working.....	15
2.5.3 Staff, safety notes for maintenance, inspection and assembly works.....	15
2.5.5 Arbitrary modifications and spare parts production	15
2.5.4 Delayed installation	15
2.5.6 Stopping and re-commissioning.....	16
2.5.7 Environmental protection.....	16
3. Transport and storage.....	16
3.1 Delivery.....	16
3.2 Transport	16
3.3 Packing.....	17
3.4 Storage.....	17
4. Product description.....	17
4.1 Components	17
4.2 Function	18
4.3 Scope of supply	19
4.4 Accessories.....	19
4.5 Type plate	19
5. Technical data	20
5.1 Product information	20
5.2 Features.....	20
5.3 Dimensions.....	20
5.4 Power supply information	21
5.4.1 Water supply.....	21
5.5 Ambient conditions	21

6.	Installation	22
6.1	Dismantling the grease separator plant.....	22
6.2	Assembling the grease separator plant.....	23
6.3	Sanitary installation	24
6.3.1	Erect the supplied separator unit	24
6.3.2	Safeguard the separator container against buoyancy.....	24
6.3.3	Connect pipelines.....	24
6.3.4	Connect inlet line	24
6.3.5	Connect outlet line	24
6.3.6	Connect disposal line (only in the case of -GD design)	24
6.4	General information, to be observed by the operator	25
6.5	Suggested installation.....	26
6.6	Power supply information and ambient conditions	26
6.6.1	Water supply.....	26
6.6.2	Ambient conditions.....	26
7.	Operation.....	27
7.1	Commissioning	27
7.1.1	Prerequisites	27
7.1.2	Commissioning steps.....	27
7.1.3	Hand-over.....	27
7.2	Operation	28
7.2.1	Documentation.....	28
7.2.2	Operation prerequisites.....	28
7.2.3	Check	28
7.2.4	Emptying and disposal.....	29
7.3	Faults.....	29
8.	Servicing	30
8.1	To be observed during all maintenance and servicing works	30
8.2	Regular maintenance and servicing works	31
9.	Repair.....	31
10.	De-commissioning	32
10.1	Disassembly	32
10.2	Disposal.....	32
10.3	Temporary close-down	32
11.	Spare parts storage and after-sales service.....	32
11.1	Maintenance and wear-and-tear parts.....	32
11.2	Order information	32
12.	Attachment	33
12.1	EC Conformity Declaration.....	33

1. Preamble

The product was developed state-of-the-art and up to its market introduction, all product-related processes are monitored by a QM system.

This operating manual for the Eco-Jet-G/-GD grease separator plant was issued with high diligence and contains information which guarantee safe operation.

If nonetheless mistakes should have slipped in or if information is missing, please advise us accordingly.

1.1 ACO service

In the case of questions on the product and its operating manual, please contact our service department.

ACO Service

Im Gewerbepark 11c



36457 Stadtlengsfeld

Service telephone +49 (0) 3 69 65 / 81 94 44

Service telefax +49 (0) 3 69 65 / 81 93 67

Email service@aco-online.de

1.2 Product identification

	Art. no.	Type	Nom. size	Illustration	Year built	Serial no.
○	3802.00.00	Eco-Jet-G	NS 2			
○	3804.00.00	Eco-Jet-G	NS 4			
○	3802.50.00	Eco-Jet-GD	NS 2			
○	3804.50.00	Eco-Jet-GD	NS 4			

For year built and serial no., refer to -
 chapter 4.5 type plate features

1.3 Product-related documents

The complete documentation consists of this operating manual and the:

- EC Conformity Declaration, Attachment  chapter. 12.1

1.4 Warranty

Notes on warranty and liability are included in our General Terms and Conditions.

1.5 Field of application of operating manual

This manual applies to the ACO Passavant grease separator plants

- **Eco-Jet-G/-GD**

The manual is used for installation, commissioning, operation, maintenance, repair and decommissioning.

All information on possible standards, test signs, quality marks or trade marks were state-of-the-art at the time this manual was printed. Deviations in figures, dimensions and weights are possible.

Instructions on existing national accident prevention regulations and environmental protection must be added to this operating manual by the plant operator.

CAUTION

■ The manual has to be kept in safe custody by the user and must always be available at installation location of plant.

1.6 Important addresses

Phone	
Telefax	

Phone	
Telefax	

Phone	
Telefax	

Phone	
Telefax	

1.7 Regulations and standards

1.7.1 Wastewater treatment by installation of grease separators

In establishments generating wastewater containing fats, grease separators as per DIN EN 1825 and DIN 4040-100 have to be installed.

The plant owner is liable for the planning and dimensioning.

■ Excerpt from:
DIN 1986-100, section 6.2.2
DIN EN 1825-2, section 4

NOTE

■ If working temperature in the separator exceeds 60° or if the plant is installed in fire hazardous areas, we recommend to use separators of stainless steel.

1.7.2 Special legal and technical regulations

(Note: the following summaries make no claim to be complete)

Legal regulations

- German Food and Feed Code
- State food hygiene regulations
- Directives for operation and monitoring of grease separator plants
- Proof of usability of specific plant (approval, test report etc.), approved by the building authorities

Technical regulations

- DIN EN 1825-2, Separator plants for fats - part 2: Selection of nominal size, installation, operation and maintenance
- DIN 4040-100, Separator plants for fats - part 100: Requirements for use of separator plants as per DIN EN 1825-1 and DIN EN 1825-2
- DIN 1988, Technical rules for drinking water installations; General; Technical rules of the „DVGW = German Technical and Scientific Association for Gas and Water“
- ATV-M 767, Wastewater from slaughterhouses and meat processing plants

■ Excerpt from:
DWA-M 167-3

1.7.3 Inflow conditions

(Note: the following summaries make no claim to be complete)

Basically, the inflow conditions of municipal drainage bye-laws as well as requirements from standards and directives apply.

Only wastewater containing fats and oils of vegetable and animal origin may be fed into a grease separator plant. The following may not be fed in grease separator plants:

- wastewater containing faeces,
- precipitation water,
- wastewater containing mineral oils and fats,
- wastewater from wet disposal plants / crushing units,
- wastewater from slaughter areas,
- solidifying fats in concentrated form (e. g. chip fat).

■ Excerpt from:
DWA-M 167-3
DIN EN 1825-2, section 7.1



1.7.4 Limited application

(Note: the following summaries make no claim to be complete)

- Substances which could affect the separating system, e. g. crushed coarse and solid matters incl. wastewater contents from wet disposal installations, may not be discharged. Generally, wastewater from such plants cannot be sufficiently pretreated by means of gravity grease separator plants and must be treated separately in consideration of condition of fats, oils and sediments.
- If detergents, rinsing agents, cleaning agents, disinfectants and additives reach the wastewater, these must be separator-friendly and may not generate any stable emulsions. Rinsing and cleaning agents should not contain or release any chlorine. (Further information on use and selection of separator-friendly rinsing agents is given e. g. in the data sheet „Commercial dishwashing & environment“, working committee dishwashing, Hagen/Germany, www.vgg-online.de).
- The well-directed use of biologically active substances, e. g. products containing enzymes to transpose grease or to enhance so-called self-cleaning, is prohibited in grease separator plants (as per DIN EN 1825 and DIN 4040-100) as well as in associated inlet lines.
- Wastewater containing a noteworthy amount of grease in non-separable, e. g. in emulsified form, e. g. from food establishments with pure rinsing operation, is effectively treated in grease separator plants to a limited extent only. Further wastewater treatment* may be required.

■ Excerpt from:
DIN EN 1825-2, section 4
DIN 4040-100, section 10.1



Wastewater treatment plant *ACO Biojet-F

* ACO Haustechnik offer relevant solutions.

1.7.5 Drain points

(Note: the following summaries make no claim to be complete)

- Drain points, e. g. floor drains (see ACO Haustechnik product catalogue or under www.aco-haustechnik.de), must be equipped with odour seals and buckets, if required, which can be taken out for cleaning purposes.
- Wastewater must be discharged into the separator plant at a free gradient of at least 1:50.
If this is not possible, the wastewater must be pumped. With pumps upstream a separator, there is the serious disadvantage that grease and wastewater are mixed intensively. This aggravates separation and preprogrammes the exceedance of limit values. These disadvantages can be nearly eliminated by the use of a special wastewater lifting plant* with reciprocating and rotary pumps (eccentric worm pumps).

■ Excerpt from:
DIN EN 1825-2, section 7.3
DWA-M 167-3

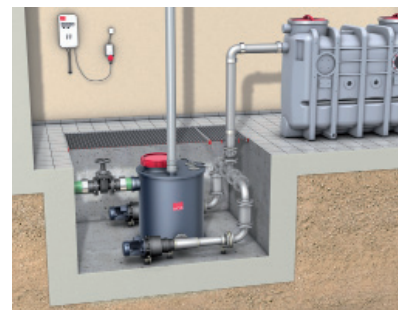

* ACO Haustechnik offer relevant solutions.

1.7.6 Installation location

(Note: the following summaries make no claim to be complete)

- Grease separator plants should be installed in the vicinity of the point of origin of wastewater, however, if possible, not in unventilated rooms or in traffic or storage areas.
- In order to avoid odour nuisance, grease separator plants should not be installed near recreation rooms and particularly not near windows or ventilation openings.
- Separator plants must be easily accessible for cleaning vehicles.
- Special operating or structural conditions may require installation of the plant away from the wastewater incident location.
- Existing drainage lines must be checked for suitable connecting height.
- Prior to installing free-standing separator plants it must be checked if the intended installation location is frostfree, has a horizontal sustainable floor (floor load), if there is enough space for erection, operation, maintenance and check of plant and if erection location is well ventilated and aerated. A water connection for replenishing and cleaning of the separator plant should be available.
- Buoyancy safeguard of free-standing plants in flood-prone areas must be guaranteed.
- The erection location of the separator plant may be discussed with the responsible food and hygiene monitoring authorities, if required.
- Only such components should be fitted which correspond to the quality requirements of quality monitoring of approved test institutes. This also applies to sludge traps and sampling units.
- Basically, only separator plants approved by the building authorities may be installed. In individual cases, an approval of the water law authorities may replace the approval of the building authorities (e. g. with direct discharge).
- Prior to the installation it must be checked if separator plant corresponds to approved planning documents. The manufacturer's installation manual has to be observed. Planning documents and installation manual must be available on site.

■ Excerpt from:
DIN EN 1825-2, section 7.2
DWA-M 167-3

1.7.7 Inlet line

(Note: the following summaries make no claim to be complete)

- In order to avoid blockages by grease, the inlet lines of the separator plant must have an incline of at least 2 % (1 : 50). If this is not possible for structural or operational reasons and/or if longer lines are required, adequate measures must be taken to avoid blockages and deposits.
 1. A thermal insulation may be required with lines which must be led through cool cellar rooms.
 2. For lines being led through building parts subject to frost, as e.g. basement garages, a trace heating system with thermal insulation may be required.
 3. The temperature of the trace heating system should be adjustable via a thermostat (control range between 25° C and 40° C) so that adaptation to seasonal changes is possible.
 4. A trace heating system is useful only when greasy wastewater occurs; we therefore recommend the use of a timer.
- The transition from downpipes to horizontal lines must be carried out with two 45° pipe bends and an intermediate section of at least 250 mm length or with a comparable pipe bend with big radius.
- Then, a stabilisation path has to be allowed for in flow direction, the length of which should correspond to at least 10 x DN of the separator inlet pipe (example: DN 100 = 1 m, DN 150 = 1.50 m).
- Following laying, the ground pipes must be checked for tightness in accordance with DIN EN 1610 in connection with the work sheet ATV-DWK-A 139.

■ Excerpt from:
DIN EN 1825-2, section 7.2
DWA-M 167-3



1.7.8 Vent line

(Note: the following summaries make no claim to be complete)

- Inlet and outlet lines at grease separator plants must be adequately ventilated. For this purpose, the inlet line must be taken above the roof as ventilation line and all connecting lines exceeding 5 m length have to be separately ventilated.
- If the inlet line above the grease separator plant does not have a separately ventilated connecting line over a length of more than 10 m, the inlet line must be fitted with an additional ventilation line closest possible to the separator plant.
- Grease separator plants must be ventilated separately above roof.
- Ventilation valves may not be used in backflow-hazardous areas and for the ventilation of containers, e. g. grease separator plants.

■ Excerpt from:
DIN EN 1825-2, section 7.4
DIN 1986-100, section 8.2

1.7.9 Disposal line

(Note: the following summaries make no claim to be complete)

- The disposal line should be laid from the grease separator to the transition point to the disposal vehicle permanently rising, turnarounds of lines by 90° elbows have to be carried out with a big radius, if possible.
- Depending on plant design, disposal lines have to be planned as pressure lines or suction lines in the required pressure stage. High-tensile connections of the individual pipes and fittings must be used.
- The disposal lines should be laid with constant diameter up to transition point; with design as suction line with min. 50 mm clear width (see DIN 1986-100).
- Pipe material of disposal pipe should be chosen in consideration of wastewater contents (extremely high solid matter portion) and the particular operating situation (high pressure/low pressure).
- In the case of grease separator plants with disposal appliances, the special manufacturer's information must be observed.

■ Excerpt from:
DWA-M 167-3

1.7.10 Sampling appliance, sampling

(Note: the following summaries make no claim to be complete)

- An appliance for sampling and inspection must be installed directly at the separator outlet and before mixing with wastewater, in the case of parallel plants, such appliance must be installed after the partial flows are merged.
- Appliances for sampling and inspection may also be fitted separately.
- The sampling point or appliance of separator plant must be freely accessible and it must be arranged in such a way that the wastewater removed flew through the separator plant.
- In order to guarantee a proper sampling and to make a tightness test of the separator plant possible, the min. dimensions have to be observed. Between inlet and outlet, a step of at least 160 mm has to be allowed for. If sufficient incline is not available, the step must be at least 30 mm.
- The DIN 4040-100, section 11 principles apply as far as requirements for representativeness of test results and limitation of error sources in sampling are concerned.

■ Excerpt from:
DIN 4040-100, section 5.5 and 11

1.7.11 Sewer connection

(Note: the following summaries make no claim to be complete)

- Separator plants must be operated backflow-free in free gradient.
- Grease separator plants, the static water level of which lies below the backflow level (normally, if not stated otherwise, height of kerbstone top edge, also refer to EN 752-I), have to be drained via a downstream lifting plant.
When selecting a lifting plant, a twin unit must be installed (specified for industrial and commercial areas) in order to guarantee uninterrupted operation in case of a pump failure. Moreover, it must be observed that behind each grease separator a further separation of grease components in the wastewater may be carried out which would result in deposits in the lifting plant container. Therefore, regular inspection in connection with the grease separator maintenance are required.
- The backflow loop bottom of the pressure line of the wastewater lifting plant must be taken above the backflow level.
- In the case of drainage installations (grease separator plants) where wastewater inflow may not be interrupted, a twin lifting plant has to be installed in accordance with the application case as per DIN EN 12050-1 or DIN EN 12050-2.
- Official regulations may limit drain water temperature at connecting point to public sewers.
- Following laying as per DIN EN 1610 in connection with worksheet ATV-DVWK-A 139, the ground pipes have to be checked for tightness.

■ Excerpt from:
DWA-M 167-3
DIN EN 1825-2, section 7.3
DIN 12056-4, section 15.2
DIN 1986-100, section 7.4

1.7.12 Disposal

(Note: the following summaries make no claim to be complete)

- Depending on specific wastewater composition, the disposal intervals have to be planned as per requirement, if possible every 2 weeks; however, at least once a month by expert personnel.
- If there are extraordinary high grease or sludge amounts, the operator must carry out checks and arrange for disposal in shorter intervals.
- When disposing of the substances removed from the separator plant, the waste legislation directives have to be observed.

■ Excerpt from:
DIN 4040-100, section 12.2
manufacturer's info



1.7.13 Maintenance

(Note: the following summaries make no claim to be complete)

- The separator plant must be serviced annually by an **expert**¹⁾ in accordance with the manufacturer's specifications.
- During maintenance works, the grease separator plant must be completely emptied and cleaned.
- The following measures have to be carried out:
 - complete emptying and cleaning of grease separator plant,
 - remove encrustations and deposits,
 - clean and check gate valves,
 - clean odourproof cover and check condition and tightness of sealing, if required,
 - clean sampling appliance, if any,
 - replenish separator plant up to static water level. The replenished water must comply with local regulations (e. g. drinking water, process water, treated wastewater from the grease separator plant).
- Determinations and works carried out must be entered into a maintenance report and be evaluated.

■ Excerpt from
DIN 4040-100, section 12.3

■ ¹⁾ **Expert**
Experts are operating personnel or assigned third parties who guarantee due to their education, knowledge and experience gained by practical work that they carry out evaluations or checks properly.

Such expert knowledge training is offered by ACO Haustechnik Service.

ACO Haustechnik Service offer relevant maintenance by an **expert** as a service. ( chapter 8.1).

1.7.14 General inspection (check)

(Note: the following summaries make no claim to be complete)

- The separator plant must be checked for its proper condition and appropriate operation by a **properly qualified technician**²⁾ prior to commissioning and thereafter in regular intervals not exceeding 5 years, following prior emptying and cleaning.
- At least the following points must be checked and registered:
 - Dimensioning of the separator plant;
 - Structural condition and tightness of the separator plant;
 - Condition of internal wall surfaces and components;
 - Inlet line design of separator plant (see para inlet line);
 - Completeness and plausibility of records in the operating log;
 - Proof of proper disposal of removed contents of separator plant;
 - Availability and completeness of required approvals and documents (permissions, drainage plans, operating and maintenance manuals, dimensioning of separator plant);
 - Register test carried out in a test report by recording possible defects.
- If defects were detected, these have to be eliminated without delay.

■ Excerpt from:
DIN 4040-100, section 12.4

■ ²⁾ **Properly qualified technician**

„Properly qualified technicians are staff members of independent companies, authorized experts or other institutions who verifiably have the required technical know-how for operation, maintenance and checking of separator plants at their disposal and who possess adequate testing equipment.

In particular cases and when larger companies are concerned, these checks may also be carried out by internally independent experts having adequate qualification and technical know-how, however who are not bound by instructions of the operator.“

ACO Haustechnik Service offer relevant general inspection by a **properly qualified technician** as a service.

1.7.15 Operating log

(Note: the following summaries make no claim to be complete)

- An operating log has to be kept in which the following has to be documented: Times and results of internal quality controls, services and checks, disposal of contents removed as well as remedy of possible defects.
- Operating logs and test reports must be kept by the operator and to be presented to the responsible, local inspecting authorities or the operators of the downstream municipal wastewater treatment plants upon request.

■ Excerpt from:
DIN 4040-100, section 12.5

Operating logs can be purchased by ACO Haustechnik Service.

2. Safety

This operating manual is an integral part of the product.

The safety notes contained in this operating manual must be read prior to operating the plant.

2.1 Proper use

2.1.1 Field of application

The separator plant is exclusively intended for separation of saponifiable oils and fats of vegetable and animal origin.

Field of application:

- Small kitchens (e. g. catering, kindergartens, ...)
- Renovations (easy bringing-in thanks to separated chambers design)

They guarantee retention from the wastewater.

2.1.2 Product design limits

The complete documentation consists of the present operating manual and the:

- EC Conformity Declaration, attachment  chapter 12.1

2.2 Plagiarisms/non-approved parts

Before its market introduction, the plant passed through all product tests and all components were checked under top load.



Non-originals of spare parts have increased to a high degree.

Installing non-approved parts will affect safety and rules out assumption of liability by ACO.

In case of an exchange, only use original parts from ACO or spare parts which were approved by ACO.

2.3 Basic risk potential

Tilting over or falling down of the plant, e. g. during transport, may lead to mechanical risks.

CAUTION 	
 Wear safety shoes!	

2.4 Symbols and reference notes explanations

This symbol is found throughout these operating instructions wherever there are job safety instructions involving health and safety risks. In all areas where there is a potential risk to human health and safety, it is particularly important that these instructions are observed and that the work is carried out carefully. All instructions involving health and safety at work must also be passed on to any other persons operating the equipment. In addition to the instructions in this operating manual, it is also essential that all of the general safety and accident prevention regulations are observed.



This symbol marks positions in the operating instructions where special care must be taken to fully observe the regulations, standards, rules and instructions, and carrying out working procedures in the proper sequence, and to prevent damage to the equipment, its components and their surroundings, and to guarantee problem-free operation.

CAUTION

This symbol marks environmental protection measures.



This bullet point marks listings.



Please also observe the notes which are directly attached to the plant.

2.5 Safety notes

2.5.1 Endangering in the case of non-observance of safety notes

Non-observance of safety notes may lead to endangering persons as well as the environment and plant.

The following may occur in the case of non-observance:

- Failure of important plant functions
- Failure of specified methods for servicing and maintenance

2.5.2 Safety-conscious working

The safety notes mentioned in this manual, the existing national accident prevention regulations as well as possible internal working, operating and safety regulations of the user have to be observed.

2.5.3 Staff, safety notes for maintenance, inspection and assembly works

Staff | The operations, servicing, inspection and assembly staff must have the appropriate qualifications to carry out the work. The operator must precisely specify and regulate the department responsible for management, the accountabilities and the supervision of the staff.

If staff do not possess the necessary qualifications, they must be trained and instructed accordingly. The operator must also ensure that the contents of the operating instruction manual are completely understood by the staff.

To protect the health and safety of the staff, the operator must take relevant action.

Safety notes for maintenance, inspection and assembly works | The user has to make sure that all maintenance, inspection and assembly works are carried out by authorised and qualified skilled personnel who have read instructions of this manual thoroughly.

Legal regulations have to be adhered to.

Prior to re-commissioning, the points mentioned in chapter „Commissioning“ have to be observed.

2.5.5 Arbitrary modifications and spare parts production

Modifications or alterations at plant are permissible only with manufacturer's prior consent.

CAUTION

- Original spare parts and accessories authorised by the manufacturer serve safety purposes.
- Using original ACO Haustechnik components guarantees safe and reliable operation of separator plant.

2.5.4 Delayed installation

If it is already known or anticipated at the time of installation that a protracted period will elapse pending commissioning, the following measures have to be taken to protect the plant:

- Protect the plant (components) against moisture and soiling.

2.5.6 Stopping and re-commissioning

The process sequence to stop plant, described in the operating manual, must be adhered to (📖 chapter 10).

NOTE

- Prior to re-commissioning, all points mentioned in section "Commissioning" have to be observed.

2.5.7 Environmental protection

Observe the waste law regulations when disposing of substances taken out of the plant.



3. Transport and storage

3.1 Delivery

The plant and its components are usually fixed to wooden pallets and are wrapped with a film.

Check if parts supplied are not damaged and complete (📖 chapter 4.3)

NOTE

- Possible damages to plant must be noted down on delivery documents to ensure proper complaint handling.

3.2 Transport

Transport to installation location	
In order to avoid damaging the plant, take the plant, standing on the wooden pallet supplied, as closely as possible to the installation location with a hand lift truck.	
Dismantling	
If the installation location cannot be reached like that, dismantle the plant (dismantling, 📖 chapter 6.1) and let 2 persons take the individual components to the installation location.	
Assembly	
Here, you re-assemble the individual components to make the complete plant (assembly, 📖 chapter 6.2)	

CAUTION



- Wear safety shoes!



- Do not suspend complete plant from crane - damage to mounting aids possible!!



- Individual components may be transported by crane. Here, do not exceed permissible lifting weight of lifting appliance and do not stand below pending loads!



3.3 Packing

The type of packaging used partially depends on the means of transport.

If not specified otherwise, the packaging complies with the packaging regulations (HPE) of the German Wooden Articles, Pallets and Export Packaging Federation, and those specified by the Federation of German Mechanical Engineering Institutes.

The plant components are mounted to wooden pallets for transport purposes.

3.4 Storage

Separator plant components should be stored in a closed, frostproof room in packed condition.

4. Product description

4.1 Components

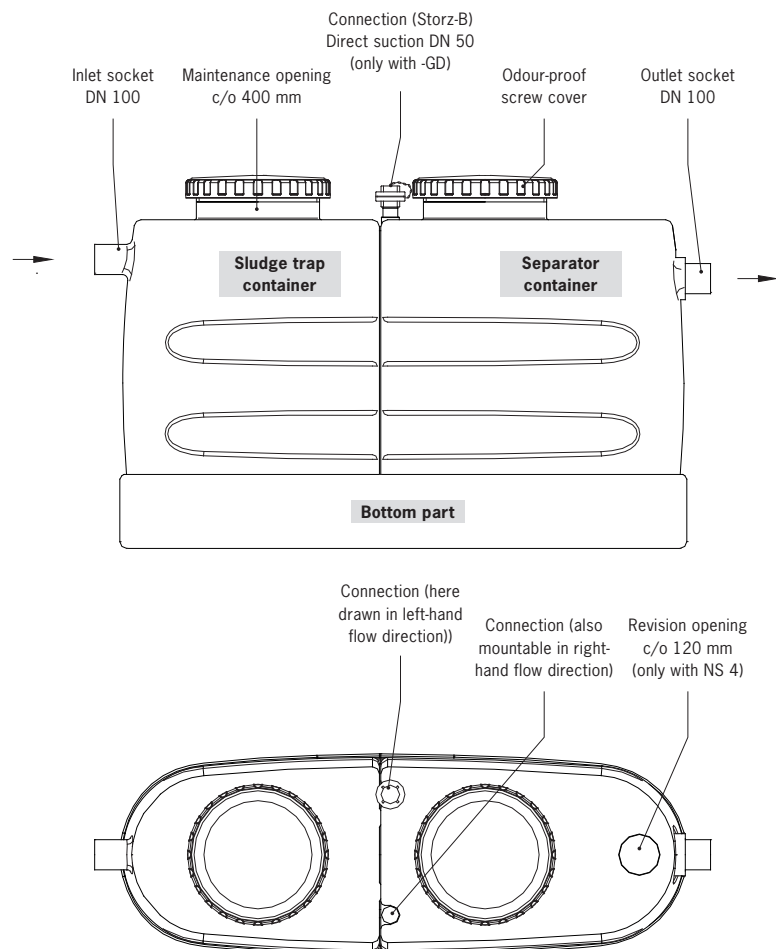

4.2 Function

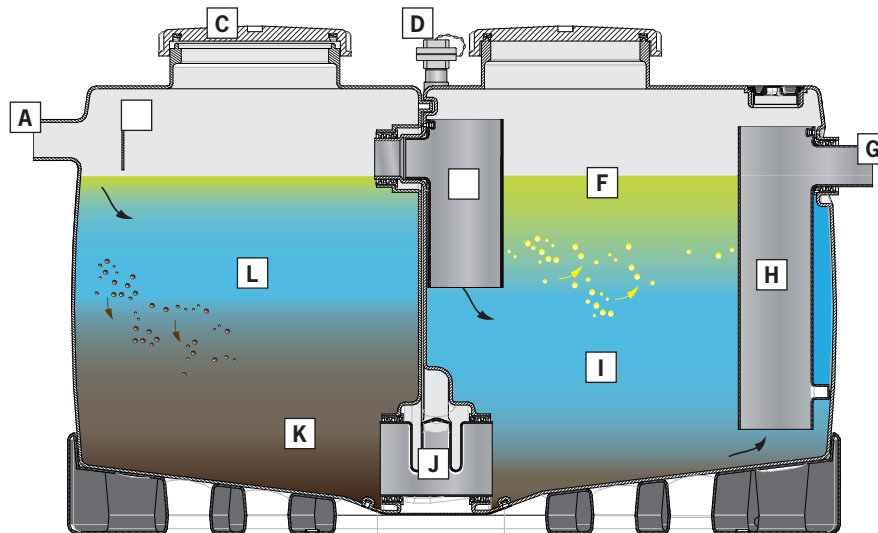

The plant consists of sludge trap **L** and separator **I**, and each, sludge trap and separator are separate containers which are arranged one after the other.

The grease separator plant works purely physically as per the gravity principle (difference in density): heavy waste-water ingredients sink to the bottom, light substances as e. g. animal oils and fats rise to the top.

Prior to commissioning, the separator must be filled with water via the connected drainage objects (via the inlet line **A**) or the maintenance openings **C** until the water flows over into the outlet **G**.

Through the inlet line **A**, the wastewater flows into the sludge trap **L** and is distributed by the baffle plate **B**. The sludge sinks to the bottom and settles in the sludge collecting chamber **K**. Via the separator inlet **E** the grease flows into the separator **I** in free gradient, rises to the top and collects in the grease collecting chamber **F**. Via the separator outlet **H**, the treated wastewater flows into the outlet line **G** in free gradient.

After connection of the suction hose to the direct suction **D**, the complete contents are pumped into the suction vehicle by the suction vehicle pump. As the sludge trap **L** and the separator **I** are connected with each other by the pipe **J**, the contents of both containers can be sucked off via a disposal line (only with -GD design) or a maintenance opening.

The cleaning process (best done with high pressure jet) should be carried out via both maintenance openings **C**. The accumulating cleaning or drain water is also sucked into the suction vehicle.

Thanks to the capsuled separator plant design, no odour nuisance occurs during disposal process (only with -GD design). Only during cleaning process must the maintenance openings **C** be opened.

Now, the separator must be replenished with water (up to the overflow into the outlet line **G**, min. 2/3 of total volume). Thanks to the connection between sludge trap **L** and separator **I** via the pipe **J**, both containers are filled at the same time.

Only then, the separator plant is again ready for operation.

4.3 Scope of supply

Check the delivery for soundness and completeness with the help of below table.

CAUTION



Do not install and operate damaged parts!

Unit	Parts	Illustration	Packing
Separator cpl.	<ul style="list-style-type: none"> - Sludge trap - Separator - Bottom part - Connecting coupling (only with -GD design) 		Wooden pallet
Documentation	<ul style="list-style-type: none"> - Operating manual - Delivery documents 	-	Foil

4.4 Accessories

For suitable accessories, as e. g. inlet gate slides, refer to ACO K9 online under www.aco-haustechnik.de.

4.5 Type plate

An adhesive label with various features of the grease separator plant is attached to the separator container.

For information or enquiries of any kind, refer to the mentioned data.



ACO Passavant GmbH
Ulsterstraße 3
36269 Philippsthal
Tel. 0 66 20 / 77-0
Fax 0 66 20 / 77-52

Eco-Jet-G/-GD

Nenngröße	Baujahr	CE
Fettabscheider	NS	
Zulassungs-Nr.	DIN EN 1825-1	
Schlammfang-Inhalt	Z-54.1-461	
Abscheider-Inhalt	210 l (NS 2), 420 l (NS 4)	
Fettspeicher-Inhalt	480 l (NS 2), 880 l (NS 4)	
Fettschichtdicke	80 l (NS 2), 160 l (NS 4)	
Artikel-Nr.	0,26 m	
Serien-Nr.	
	

NOTE

Please take the data from the original type plate of the plant.

5. Technical data

5.1 Product information

ACO product benefits

- Approved stability: 25 years (minimum lifetime)
- Thanks to tripartite plant design, plant can also be brought in in difficult-to-access installation locations.
- Direct emptying without odour nuisance (only with -GD design)
- Low weight

- Grease separator plant as per DIN EN 1825 and DIN 4040-100
- For installation in rooms - frostfree
- With separate sludge trap
- With disposal connection DN 50 and Storz-B coupling R 2"
- Odourproof maintenance opening, diameter: 450 mm
- Connections for inlet and outlet as per DIN EN 877
- ACO Passavant system
- Official test sign Z-54.1-461

5.2 Features

Nominal size	Contents			Weight		Art. no.	
	Sludge trap [l]	Grease stor. [l]	Total volume [l]	Empty [l]	Filled [l]	-G Type	-GD
NS 2	210	80	480	75	555	3802.00.00	3802.50.00
NS 4	410	160	880	115	995	3804.00.00	3804.50.00

5.3 Dimensions

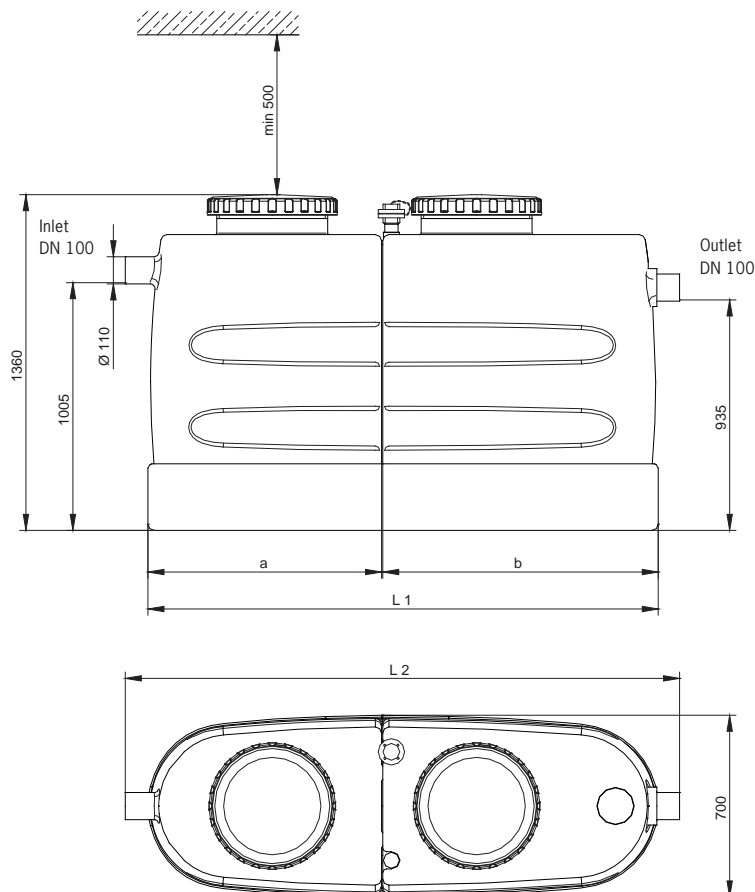

Nominal size	Dimensions			
	L1 [mm]	L2 [mm]	A [mm]	B [mm]
NS 2	1180	1360	510	660
NS 4	2070	2250	945	1115

5.4 Power supply information

5.4.1 Water supply

For general cleaning works and internal cleaning of separator plant, a fresh water tap R ¾" should be provided in the vicinity of plant, if possible. Warm water connection should preferably also be available.

5.5 Ambient conditions





The installation location of the plant must be easily accessible, i. e. a distance (to the wall or to the appliance) of at least 0.6 m must be available round the components which have to be operated and maintained.

It must be possible to lay inlet and outlet line, disposal line and possible vent line to the inside or to the outside.

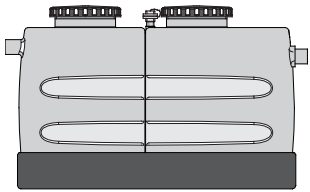
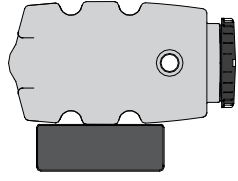
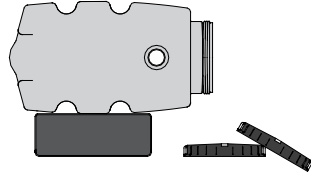
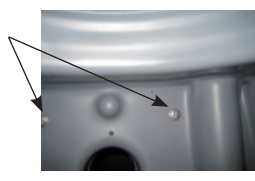
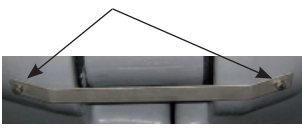
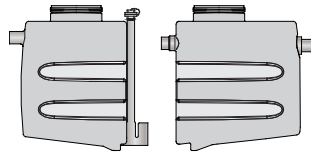
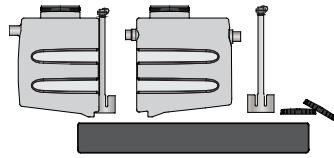

For accessories (e. g. inlet slide, coarse trap, sampling pipe etc.), relevant space is required.

6. Installation

6.1 Dismantling the grease separator plant

Beginning	Step 1	Step 2
 <p>Grease separator plant complete</p>	 <p>Turn mounted group - sludge trap and separator containers - to the side and lay down.</p>	 <p>Remove screw covers of maintenance openings.</p>
Step 3	Step 4	Step 5
 <p>Sludge trap and separator containers are bolted with 2 screw joints in the upper area (reachable via the maintenance openings). Dismount both connections.</p>	 <p>Sludge trap and separator containers are screwed down with a holder at the outside bottom. Dismount this connection.</p>	 <p>Pull apart sludge trap and separator containers.</p>
Step 6	Transport to installation location	
 <p>Dismantled grease separator plant (possibly also with dismantled disposal line).</p>	 <p>Take single components to the installation location with 2 persons.</p>	<p>CAUTION </p> <p>Please observe the safety notes in  chapter 3.2</p>

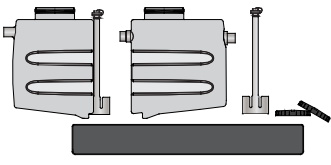
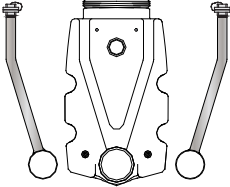
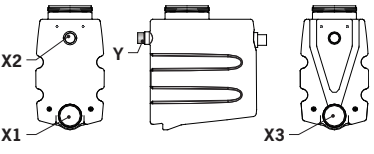
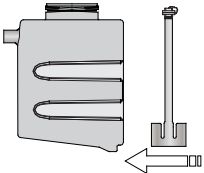
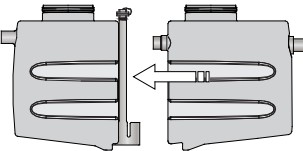
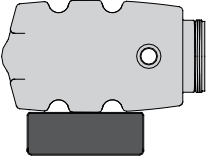
6.2 Assembling the grease separator plant

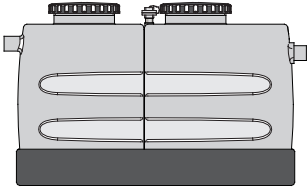
Beginning	Step 1	Step 2
<p>Separator container</p> 	<p>Separator container</p> 	<p>Sludge trap- I Separator container I</p> 
<p>Dismantled grease separator plant</p>	<p>Disposal line can be mounted by turning to left or right connection (viewed in flow direction).</p>	<p>Grease socket seal X1-3 and spigot Y well.</p>
Step 3	Step 4	Step 5
		
<p>Slide disposal line with connecting coupling (with -GD design) or connecting pipe in socket sealing X1 of sludge trap container.</p>	<p>Position sludge trap and separator containers with the sockets appropriately, implement in socket sealing X2+3 and push containers together.</p>	<p>Turn mounted group - sludge trap and separator containers - to the side (if not yet done).</p>
Step 6	Step 7	Step 8
		
<p>Bolt down sludge trap and separator containers with the holder at the outside bottom.</p>	<p>Bolt down sludge trap and separator containers with 2 screw joints in the upper area (reachable via the maintenance openings).</p>	<p>Apply screw covers of maintenance openings and erect unit on bottom part. Grease separator plant is complete.</p>

6.3 Sanitary installation

6.3.1 Erect supplied separator unit

Align separator horizontally on the level floor.

Relevant technical data

-  chapter 1.7.6.

6.3.2 Safeguard separator container against buoyancy

In order to avoid buoying of the separator container in case of a flood, it must be safeguarded in situ by appropriate measures.

Relevant technical data

-  chapter 1.7.6.

6.3.3 Connect pipelines

The plant may in no way be used as anchor point for the pipeline. Pipeline expansions due to temperature fluctuations must be balanced by suitable measures in order not to load the plant. In the case of non-observance, leaking spots may occur which could lead to discharge of wastewater.

CAUTION

- No pipe forces and moments may affect the plant.

6.3.4 Connect inlet line

An inlet socket (pipe external diameter **Ø 110 mm**) is marked with inlet at the separator plant (sludge trap container). Here, the in situ inlet line must be connected.

Relevant technical data

-  chapter 1.7.7.

6.3.5 Connect outlet line

An outlet socket (pipe external diameter **Ø 110 mm**) is marked with outlet at the separator plant (separator container). Here, the in situ outlet line must be connected.

Relevant technical data

-  chapter 1.7.11.

6.3.6 Connect disposal line (only with -GD design)

The separator has got a direct connection for the disposal of separator contents.

A connecting coupling DN 50 / Storz-B system is contained in scope of supply.

If this connection cannot be reached by the suction vehicle, a relevant disposal line can be laid. The connecting coupling with blind cover can be dismantled from disposal line of separator and be screwed onto the end of the local disposal line. For a complete external wall connection box for the disposal, vent and water connection, please refer to our supply range (www.aco-haustechnik.de -K9 online).

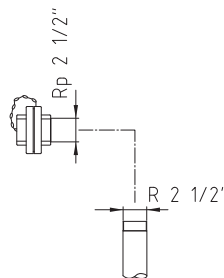

ACHTUNG

- The line must be laid in min. DN 65 - PN 6 with gradient to the separator. Compensators have to be used to avoid sound transmissions and vibration absorptions. The max. length of the disposal line is dependent upon performance of suction pump/suction vehicle.

6.4 General information, to be observed by the operator

(Note: the following summaries make no claim to be complete)

- **Compliance with legal and technical regulations**

- For installation, operation, maintenance and check of grease separator plants, the special legal and technical regulations have to be adhered to (see DIN EN 1825, DIN 4040-100, notes in chapter 1.7.2).

- **Correct dimensioning of separator**

- Correct dimensioning of separator plant as per DIN EN 1825 has to be observed.

- **Discharge conditions**

- Basically, the discharge conditions of municipal drainage bye-laws as well as requirements of standards and directives apply (see chapter 1.7.3).

- **Installation principles**

- Existing drainage lines must be checked for suitable connecting heights. In accordance with DIN EN 1825 or DIN 4040, the materials used for inlet and outlet pipes must be stable to wastewater. Depending on separator nominal size and pipe gradient, required pipe cross-sections have to be observed as per the pertinent standards.
- Separator plants have to be operated backflow-free. Grease separator plants, the outlet (pipe bottom) of which lies below the backflow level, have to be connected to the sewers via wastewater lifting plants.
- Buoyancy-safeguard of grease separator plants has to be guaranteed.
- For sampling, a sampling possibility (design in accordance with pertinent standard) has to be arranged for.
- The installation location of the grease separator plant must be as close as possible to the place where the wastewater occurs in order to avoid deposits and blockages in the inlet line by cooling and solidifying grease. The installation location must be frostfree and have a horizontal, sustainable floor (observe floor load). There must be enough space for erection, operation, maintenance and check of grease separator plant und location must be well aerated and ventilated.
- It must be checked if the grease separator plant is in conformity with approved planning documentation. The manufacturer's installation and operating manual has to be observed and be kept at the installation location, together with the planning documents.
- The plant's type plant must be easily legible any time.
- Necessary connecting lines must be strainlessly laid..
- When installation is finished, plant must be checked visually for tightness, process and result have to be recorded, in accordance with DIN 4040-100.

6.5 Suggested installation

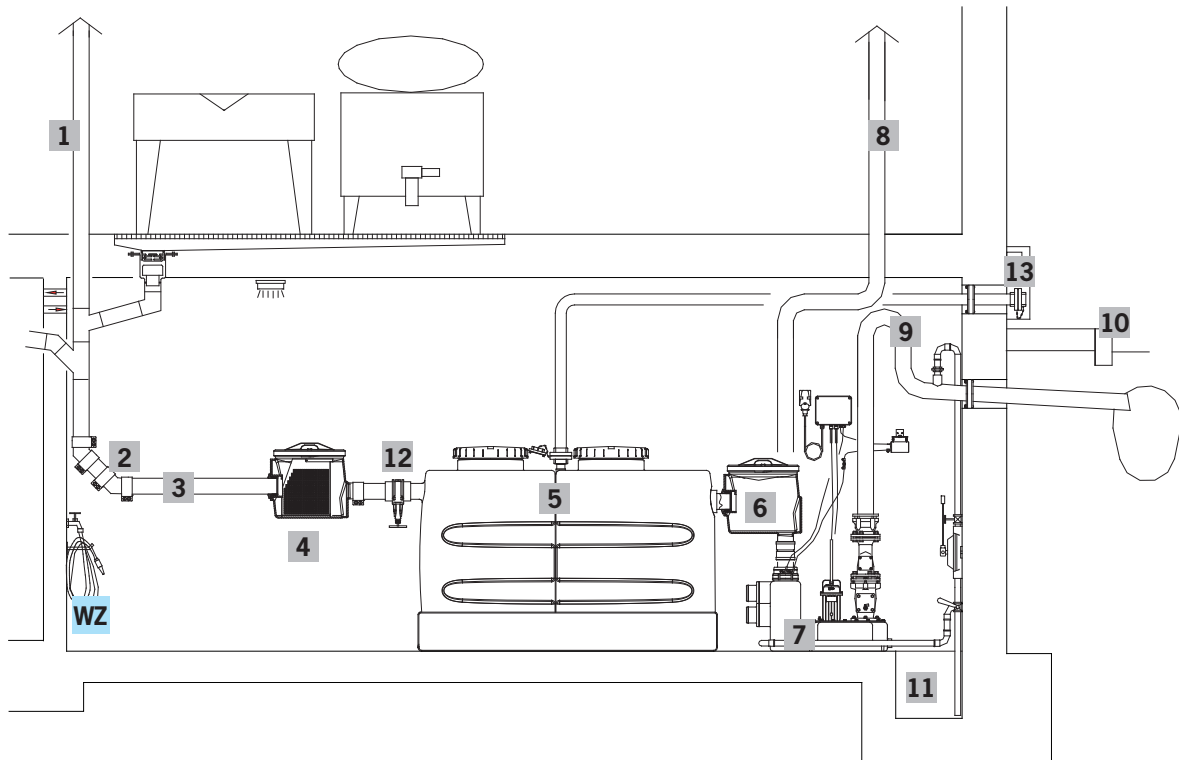

Legend

1	Ventilation above roof	6	Sampling pot	11	Pump sump with manual diaphragm pump
2	Transition downpipe to horizontal inlet line	7	Wastewater lifting plant	12	Inflow slide
3	Stabilising path	8	Ventilation lifting plant above roof	13	Connecting box
4	Coarse trap	9	Backflow loop		
5	Eco-Jet -G/-GD (here, -GD depicted)	10	Backflow level		

6.6 Power supply information and ambient conditions

6.6.1 Water supply

For general cleaning works and internal cleaning of separator plant, a fresh water tap **WZ** (R ¾") should be provided in the vicinity of plant, if possible. Warm water connection should preferably also be available.

6.6.2 Ambient conditions

Prior to installing free-standing separator plants it must be checked if the intended installation location is frostfree, has a horizontal sustainable floor (floor load), if there is enough space for erection, operation, maintenance and check of plant and if erection location is well ventilated and aerated.

Buoyancy safeguard of free-standing plants in flood-prone areas must be guaranteed.

7. Operation

7.1 Commissioning

7.1.1 Prerequisites

- All plumbing works (📖 chapter 6.3) must be finished.
- Pipelines must be flushed through.
- The separator plant was thoroughly cleaned (from possibly accruing construction waste).
- General inspection of the grease separator plant was carried out by a properly qualified technician as per DIN 4040-100 and possible objections were remedied.
- Greasy wastewater may not yet enter the plant.

NOTE

Following persons should be present during commissioning:

- The plumber
- Operating personnel / operator
- The disposal company

7.1.2 Commissioning steps

- 1 Open gate valve in inlet and outlet of plant (if available).
 - 2 Start filling process of separator plant via the inlet line or the maintenance openings.

Filling process is finished if water flows out of separator outlet or if at least 2/3 of water filling is reached.
 - 3 Check plant visually for tightness, report procedure and result.
- Plant is ready for operation. Greasy wastewater may enter the plant.

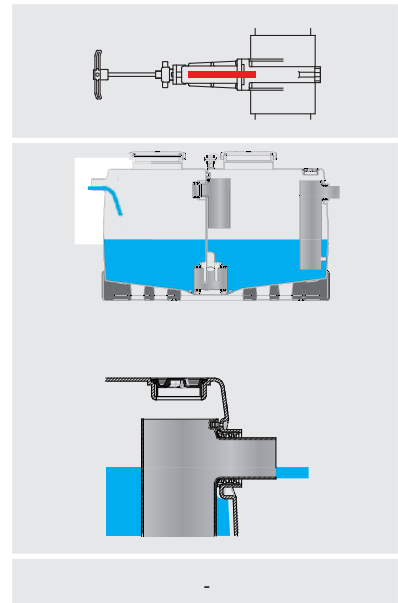

7.1.3 Hand-over

After the briefing, the operating manual, the operating log and the hand-over protocol have to be handed over to the operator.

CAUTION

- The documents must be permanently available at installation location of separator plant.

7.2 Operation

7.2.1 Documentation

The plant documentation, consisting of:

- operating log
- inventory documentation
- permission, approval
- acceptance certificate
- operating manual
- official test report

must be available at the location of the plant.

CAUTION



- Service of plant (operation, maintenance and commissioning) must be carried out by expert and trained staff. They must be familiar with the operating manual, the specifications and pertinent regulations on working safety and accident prevention contained therein.
- An operating log must be kept.

7.2.2 Operation prerequisites

Only such detergents, rinsing, cleaning and disinfection agents and additives may be discharged into the wastewater which do not contain or release any chlorine, which are separator-friendly and do not generate any stabile emulsions.

To further reduce the total wastewater load, we recommend the following:

- Remove leftovers from dishes to be rinsed consequently
- Prerinse the dishes without cleaning agents and insert into dishwasher only then
- Reduce dosage of dishwasher detergents in agreement with the detergents suppliers, if justifiable for hygiene reasons.

CAUTION



- Discharge limitations (DIN EN 1825-2, 7.1): Only wastewater containing fats and oils of vegetable and animal origin may be discharged into a separator plant.
- The following may not be fed:
 - no wastewater containing faeces (black water)
 - no rain water and no wastewater containing light liquids (e. g. fats and oils of mineral origin).
- Substances which could affect the separating system may not be discharged.
- The regulations of approval by building authorities and those of the pertinent standards for plant operation have to be observed (also refer to chapter 1.7.2).

7.2.3 Check

Every 1-2 days, a visual check of plant and its connections should be carried out.

Operability of plant should be checked regularly, at least once a week, by a skilled person.

This check includes the following measures:

- Visual check of separator plant and its connections
- Determination of sludge incidence in the sludge trap
- Determination of grease layer thickness or reaching of max. grease storage volume (indications as per type plate).

NOTE

- If faults are detected during the check, these have to be eliminated at once. The check carried out, the possible defects and their remedies have to be recorded in the operating log.

7.2.4 Emptying and disposal

The operator is bound to utilise the separated solid matters. He has to make sure that disposal and evacuation is carried out by approved companies.

Dependent upon the prevailing wastewater composition, the disposal intervals have to be carried out as per requirement, if possible every 2 weeks, however at least once a month by expert staff.

The timely determination of the required disposal works is carried out with the help of measured grease layer and sludge layer thicknesses.

Besides the check works, the disposal works comprise following works:

- complete emptying
- cleaning
- replenishing with water
- cleaning of drain channel, coarse trap or sampling appliance (if available).

NOTE



- For emptying of the separator plant and for disposal of contents, DIN EN 1825 in conjunction with DIN 4040-100 and the pertinent waste law have to be observed.

7.3 Faults

NOTE

- In the case of faults and enquiries during the operation of the plant, the ACO service department may be contacted: Phone +49 (0) 3 69 65 - 81 94 44

8. Servicing

8.1 To be observed during all maintenance and servicing works

General

- Always retighten any connections loosened during maintenance or servicing works.
- All contents of the separator plant removed during operation, and any parts of the plant which are replaced, must be disposed of in accordance with the environmental protection regulations.

CAUTION



Conservation of value and performance, maintenance contract

To maintain the value and performance of the plant as well as the warranty prerequisites, we recommend 1 - 2 servicings annually (refer to  chapter.1.7.13)

We recommend to have the regular maintenance and servicing works carried out directly by the manufacturer, ACO Passavant GmbH. This does not only guarantee permanent operational reliability, but you also benefit from revisions and upgradings which are carried out in the course of our product development.

If you require a quotation for a **maintenance contract**, please fill out below section and fax it to **no: +49 (0) 3 69 65 / 81 93 67**.

In case of any questions, please contact our service, **tel.: +49 (0) 3 69 65 / 81 94 44**.

Enquiry for a maintenance contract for separator plant

Please send me a non-binding quotation for regular maintenance of the plant.

Fax no: +49 (0) 3 69 65/81 93 67

Surname, name _____

Post code, City _____

Type as per type plate _____



Street, house number _____

Installation date _____

Telephone/Telefax number _____

8.2 Regular maintenance and servicing works

Maintenance works	Interval	Person in charge
Visual check of separator plant	every 1-2 days	Operator
Disposal of complete separator plant contents	upon requirement; if possible every 2 weeks, however at least monthly	Expert or disposal contractor
Carry out check / maintenance of complete separator plant for condition and function following prior emptying and cleaning	every 6 months	Expert or ACO Service
General inspection of separator plant	every 5 years	Technician
Tightness check of all pipe and hose connections	upon requirement	Operator, expert or ACO Service

9. Repair

For repair works, please contact the ACO Service department
 Telephone +49 (0) 3 69 65 / 81 94 44
 Fax +49 (0) 3 69 65 / 81 93 67
 Email: service@aco-online.de

10. De-commissioning

10.1 Dismantling

Avoid water inflow, empty lines and separator, disassemble separator plant.

10.2 Disposal

The separator plant consists of re-usable materials. They must be disposed of in accordance with local regulations.



10.3 Temporary close-down

1. Protect plant against moisture.
2. Operate functional parts (e. g. gate valve) from time to time to avoid seizing.
3. Depending on duration and surroundings, store plant in a dry place.

NOTE

- In the case of decommissioning, paras 1 - 3 are recommendable.

11. Spare parts storage and after-sales service

11.1 Maintenance and wear-and-tear parts

Please contact the **ACO Service** department, indicating type and year built of separator plant.

ACO Service:
Telephone +49 (0) 3 69 65 / 81 94 44
Fax +49 (0) 3 69 65 / 81 93 67
Email service@aco-online.de

11.2 Order information

In the case of spare parts order or queries, mention the following (take data from the type plate):

- Type of separator plant
- Year built
- Art. number
- Serial number

CAUTION

- ACO Haustechnik point out expressly that maintenance and wear parts as well as accessories not corresponding to the original are neither tested nor released.

Fitting and/or use of such products may negatively change structurally given separator plant features and may thus affect the active and/or passive safety.

ACO Haustechnik do not assume any liability and warranty for the use of non-original parts and accessories.

12. Attachment

12.1 EC Conformity Declaration

Eco-Jet-G and -GD

Grease separators - full disposal/separated chambers design -polyethylene (PE-HD)/
free-standing installation

The manufacturer:

- ACO Passavant GmbH
Ulsterstrasse 3
36269 Philippsthal

herewith certifies that the machine plants:

- Eco-Jet-G and -GD

are in conformity with directive:

- EG-RL 2006/42/EG Machine Directive

Plant components are in conformity with further guidelines:

- - -

The following harmonized standards were applied:

- DIN EN 1825 2004-12 edition
- DIN 4040-100 2004-12 edition

The following approved bodies were employed:

- DIBt - Berlin Grease separators: official test sign Z-54.1-461

Addition:

- For the used polyethylene material, the fire behaviour class E as per EN ISO 13501-1:2002, section 10.3 was verified.

Remark:

- The separators separate fats of vegetable and/or animal origin from wastewater by gravity in order to protect drainage systems.

Competent documentary agent:

- Mr Alexander Brinkhoff ACO Passavant GmbH
Im Gewerbepark 11c
36457 Stadtlengsfeld

Philippsthal, 28.09.2010

- Mr Ralf Sand  General Manager
ACO Passavant GmbH

Operating manual
0150.34.07_V01
February 2011 edition

